

Filter	Size					
	0	05		1	2	
Part no.	HZE0F08G	HZE05F08G	HZE05F10G	HZE1F10G	HZE1F15G	HZE2F15G
Connections	G1/4	G1/4	G3/8	G3/8	G1/2	G1/2
Filtration rating (µm)	5	5		5		5
Nominal flow rate (NI/min) ^(A)	1100	1500	2000	2300	2500	5000
Max supply pressure (bar-MPa-psi)	10 - 1 - 145		10 - 1 - 145		10 - 1 - 145	
Fluid	compressed air	compressed air		compressed air		compressed air
Ambient temperature (°C)	0 ÷ 60	0 ÷ 60		0 ÷ 60		0 ÷ 60
Condensation drain capacity (cm ³)	12	40		45		80
Condensation drain	manual	manual		manual		manual
Weight (Kg)	0,10	0,17		0,31		0,55
Mounting position	vertical	vertical		vertical		vertical

(A) = supply pressure 7 bar - Δp 0,5 bar

Size 0

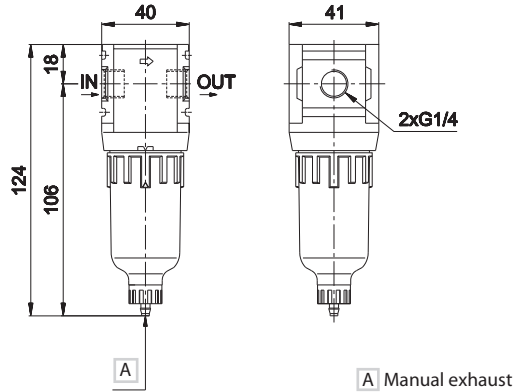

Size 05

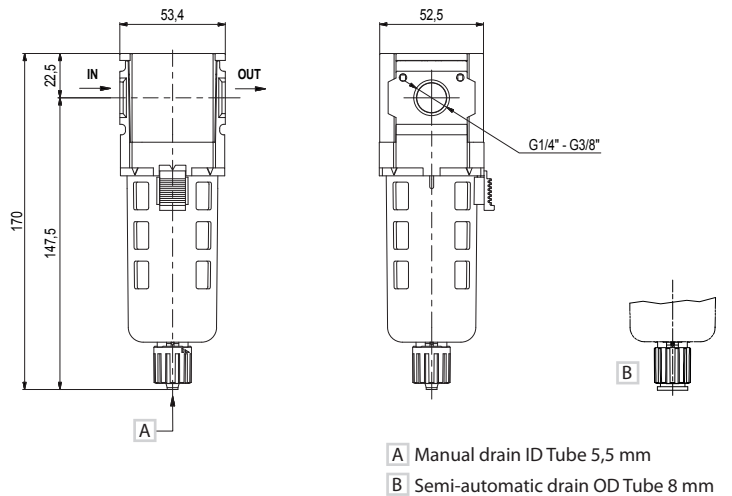

Size 1 - 2

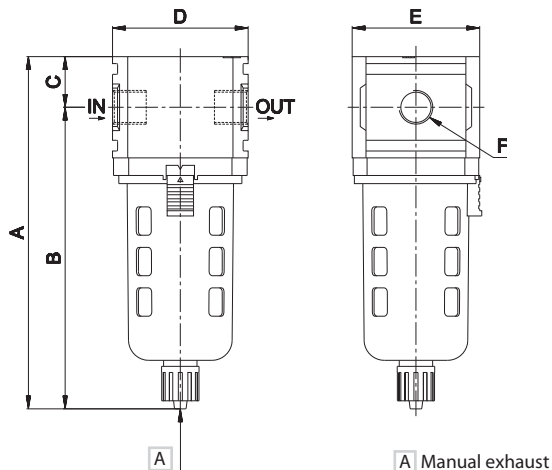

Size	A	B	C	D	E	F
1	180	157	23	63	63	G3/8-G1/2
2	195	172	23	80	80	G1/2