

Lubricator	Size					
	0	05		1	2	
Part no.	HZE0L08G	HZE05L08G	HZE05L10G	HZE1L10G	HZE1L15G	HZE2L15G
Connections	G1/4	G1/4	G3/8	G3/8	G1/2	G1/2
Nominal flow rate (NI/min) (A)	1400	1800	3800	4400		7000
Max supply pressure (bar-MPa-psi)	10-1-145	10-1-145		10-1-145		10-1-145
Fluid	filtered air	filtered air		filtered air		filtered air
Ambient temperature (°C)	0 ÷ 60	0 ÷ 60		0 ÷ 60		0 ÷ 60
Bowl capacity (cm³)	20	70		85		170
Weight (Kg)	0,10	0,21		0,31		0,46
Mounting position	vertical	vertical		vertical		vertical
Recommended oil	ISO VG 32	ISO VG 32		ISO VG 32		ISO VG 32
Minimum working flow (l/min)	15	30		30		65

(A) = supply pressure 7 bar - Δp 0,5 bar

Size 0

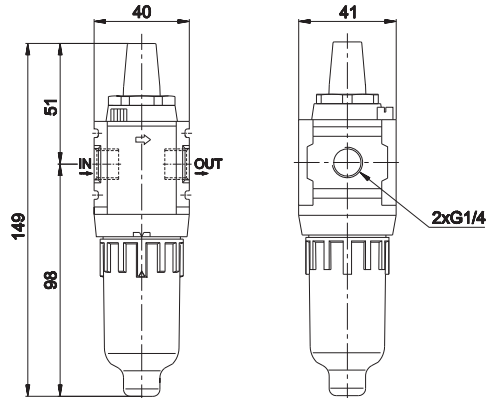

Size 05

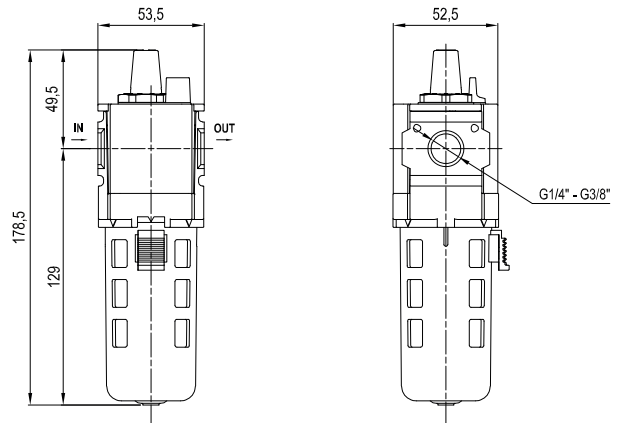

Size 1 - 2

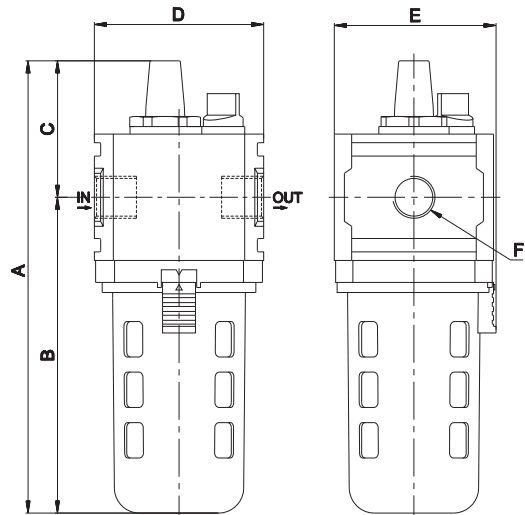

Size	A	B	C	D	E	F
1	182,5	130	52,5	63	63	G3/8-G1/2
2	201,5	148	53,5	80	80	G1/2