

Regulator	Size					
	0	05		1	2	
Part no.	HZE0R08GM	HZE05R08GM	HZE05R10GM	HZE1R10GM	HZE1R15GM	HZE2R15GM
Connections	G1/4	G1/4	G3/8	G3/8	G1/2	G1/2
Nominal flow rate (NI/min) ^(A)	1000	1900	2500	2800	3500	5000
Max supply pressure (bar-MPa-psi)	10 - 1 - 145	10 - 1 - 145		10 - 1 - 145		10 - 1 - 145
Pressure adjustment relieving (bar)	0,5 ÷ 8,5	0,5 ÷ 8,5		0,5 ÷ 8,5		0,5 ÷ 8,5
Pressure gauge (standard supplied)	HZ9464G	HZ9464G		HZ9464G		HZ9464G
Pressure gauge port	G1/8 ^(B)	G1/8 ^(B)		G1/8 ^(C)		G1/8 ^(C)
Fluid	filtered air	filtered air		filtered air		filtered air
Ambient temperature (°C)	0 ÷ 60	0 ÷ 60		0 ÷ 60		0 ÷ 60
Weight (Kg)	0,16	0,31		0,45		0,70
Mounting position	any	any		any		any

(A) = supply pressure 7 bar, outlet pressure 5 bar - Δp 1 bar

(B) = upon request (replace HZ9464G gauge with HZE7Z480 square adaptor G1/8, to be ordered separately)

(C) = standard supplied (replace HZ9464G gauge with HZE7Z480 square adaptor G1/8 placed on the rear side)

Size 0

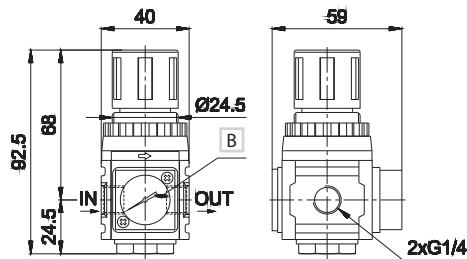
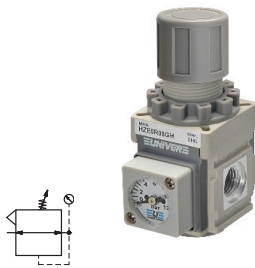

B HZ9464G gauge standard supplied

Size 05

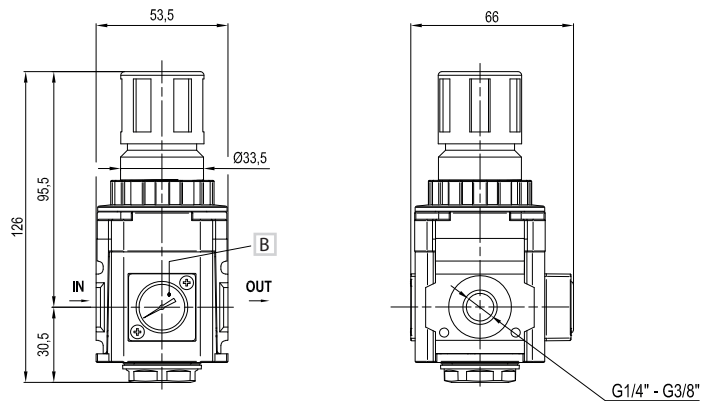

B HZ9464G gauge standard supplied

Size 1 - 2

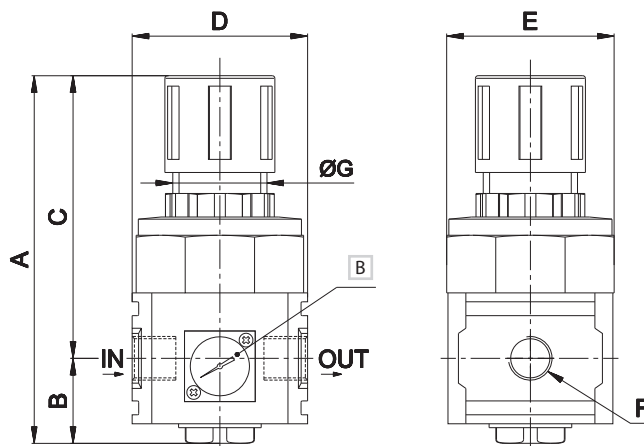

B HZ9464G gauge standard supplied

Size	A	B	C	D	E	F	G
1	136	32,5	103,5	63	63	G3/8-G1/2	35
2	145	34,5	110,5	80	80	G1/2	40