

AF

G1/8 ÷ G1 1/2 Poppet valves for compressed air

- Wide range: G1/8 - G1/4 - G3/8 - G1/2 - G3/4 - G1 - G1 1/2
- Original Univer poppet system appreciated for decades
- Suitable for applications where high flow rate and high cycles rates are required
- G1 - 2/2 version for blowing

Available ATEX version upon request

CE Ex II 2Gc IIC T5 II 2Dc T100°C

CE Ex II 3 GD c nA II T5-10°C ≤ Ta ≤ 45°C



TECHNICAL CHARACTERISTICS

Ambient temperature								+50 °C max
Fluid temperature								-5 ÷ +60 °C
Fluid	50 µm filtered air, with or without lubrication							
Commutation system	poppet							
Ways/Positions	2/2 NC (upon request), 3/2 NC, 3/2 NO, 3/2 NC-NO							
Pressure	max 10 bar							
Control	pneumatic, indirect electropneumatic							
Return	pneumomechanical spring							
Connections	G 1/8	G 1/4	G 3/8	G 1/2	G 3/4	G 1	G 1 1/2	
Nominal Ø (mm)	5,5	8	10	15	19	25	39	
Nominal flow rate (NI/min)	580	1100	1500	5400	6500	13500	35000	

CONSTRUCTIVE CHARACTERISTICS

Valve body	G1/8 ÷ G1 = zamak G1 1/2 = aluminium
Seals	polyurethane conical poppets and Vulkollan diaphragm
Actuators	G1/8 ÷ G1 = zamak G1 1/2 = aluminium
Spool	G1/8 ÷ G3/8 = aluminium G1/2 ÷ G1 1/2 = steel + plastic

ELECTRIC CHARACTERISTICS

	G1/8 G3/8	G1/4 ÷ G1 1/2
Electropilot	U1	U2
Coil	DA	DB
Power consumption	3,5 W (DC) - 5 VA (AC)	11 W (DC) - 10 VA (AC)
Connector	AM-5110	AM-5111
Voltage	12 V DC - 24 V DC - 24 V AC - 110 V AC - 230 V AC	
Manual override	impulse screw - 2 positions	

G1/8 - G1/4 - G3/8 Electrovalves



3/2 NC G1/8
AF-2500

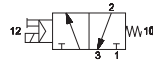

3/2 NO G1/8
AF-2501

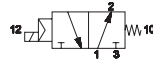

3/2 NC G1/4 - G3/8
AF-2510
AF-2517
AF-2520
AF-2524

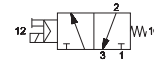

3/2 NO G1/4 - G3/8
AF-2511
AF-2518
AF-2521
AF-2525

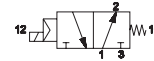

	Connect.	Control	Return	Flow rate	Ø	Resp. Time (ms)		Pressure bar		Weight	Coil	Part no.
						En.	De-en.	min.	max.			
3/2 NC	G1/8	electric amplified	pneumomechanical spring	580 (NI/min)	5,5 mm	15	20	1,5	10	0,25	U1	AF-2500
	G1/4	electric amplified	pneumomechanical spring	1100	8	20	23	1,6	10	0,58	U1	AF-2510
	G1/4	electric amplified	pneumomechanical spring	1100	8	20	23	1,6	10	0,70	U2	AF-2517
	G3/8	electric amplified	pneumomechanical spring	1500	10	20	23	1,6	10	0,56	U1	AF-2520
	G3/8	electric amplified	pneumomechanical spring	1500	10	20	23	1,6	10	0,70	U2	AF-2524
3/2 NO	G1/8	electric amplified	pneumomechanical spring	580	5,5	15	20	1,5	10	0,25	U1	AF-2501
	G1/4	electric amplified	pneumomechanical spring	1100	8	15	20	1,6	10	0,58	U1	AF-2511
	G1/4	electric amplified	pneumomechanical spring	1100	8	15	20	1,6	10	0,70	U2	AF-2518
	G3/8	electric amplified	pneumomechanical spring	1500	10	15	20	1,6	10	0,56	U1	AF-2521
	G3/8	electric amplified	pneumomechanical spring	1500	10	15	20	1,6	10	0,70	U2	AF-2525

G1/8

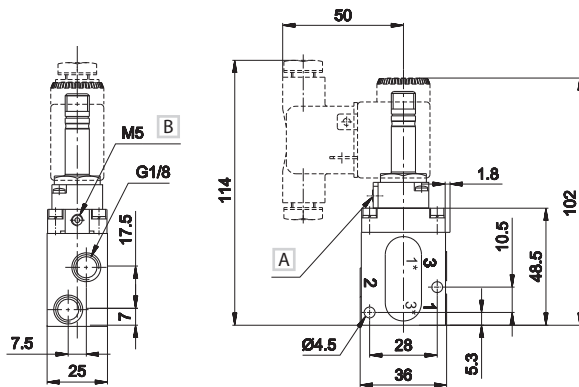

- NC
1 = Supply port
2 = Use
3 = Exhaust
- NO
1* = Supply port
2 = Use
3* = Exhaust

- A Manual override
B External servoassistance of the pilot

G1/4 - G3/8

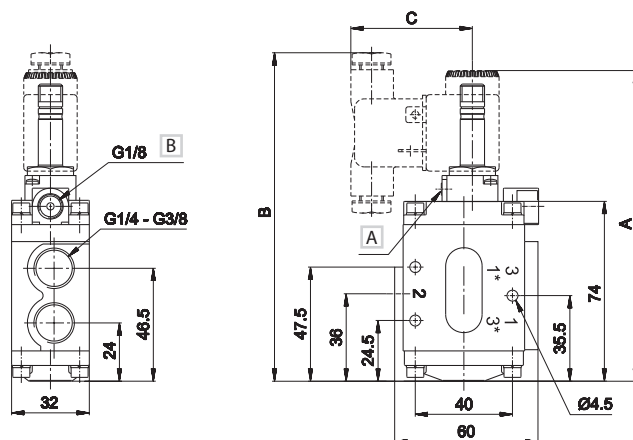

- NC
1 = Supply port
2 = Use
3 = Exhaust
- NO
1* = Supply port
2 = Use
3* = Exhaust

- A Manual override
B External servoassistance of the pilot

	A	B	C
U1	129	136	50
U2	140,5	150	51,5

Upon request:

- external servoassistance of the pilot
- G1/4 - G3/8 U2 without manual override
- 2/2 version insert plug on the drain

Electrovalves are supplied without coil, connector and locking ring

G1/2 - G3/4 - G1 - G1 1/2 Electrovalves



3/2 NC G1/2 - G3/4 - G1
 AF-2530
 AF-2540
 AF-2545

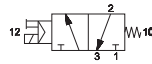

3/2 NC G1 1/2
 AF-2565

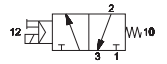

3/2 NO G1/2 - G3/4 - G1
 AF-2531
 AF-2541
 AF-2546

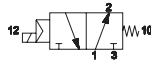

3/2 NO G1 1/2
 AF-2561

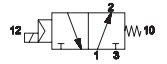

	Connect.	Control	Return	Flow rate	Ø	Resp. Time (ms)		Pressure bar		Weight	Coil	Part no.
						En.	De-en.	min.	max.			
3/2 NC	G1/2	12 electric amplified	10 pneumomechanical spring	5400	15	17	27	2	10	1,19	U2	AF-2530
	G3/4	12 electric amplified	10 pneumomechanical spring	6500	19	17	27	2	10	1,13	U2	AF-2540
	G1	12 electric amplified	10 pneumomechanical spring	13500	25	20	32	2,2	10	1,62	U2	AF-2545
	G1 1/2	12 electric amplified	10 pneumomechanical spring	35000	39	47	22	2,5	10	2,27	U2	AF-2565
3/2 NO	G1/2	12 electric amplified	10 pneumomechanical spring	5400	15	30	22	3	10	1,19	U2	AF-2531
	G3/4	12 electric amplified	10 pneumomechanical spring	6500	19	30	22	3	10	1,13	U2	AF-2541
	G1	12 electric amplified	10 pneumomechanical spring	13500	25	28	23	3	10	1,62	U2	AF-2546
	G1 1/2	12 electric amplified	10 pneumomechanical spring	35000	39	55	20	3	10	2,27	U2	AF-2561

G1/2 - G3/4 - G1

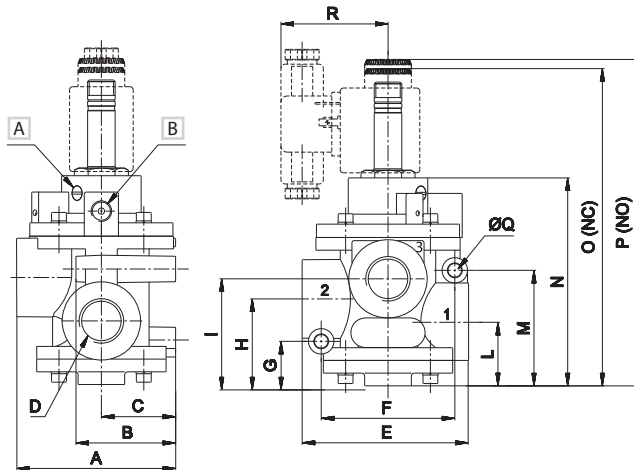

1 = Supply port
 2 = Use
 3 = Exhaust

A Manual override
 B External servoassistance of the pilot

	A	B	C	D	E	F	G	H	I	L	M	N	O	P	Q	R
G1/2	75	47	35	G1/2	78,5	63	21	41	50,5	30	54,5	100	150	154	6,4	50,5
G3/4	75	47	35	G3/4	78,5	63	21	41	50,5	30	54,5	100	150	154	6,4	50,5
G1	89	55	40	G1	101	76	25,5	51	64	38	62,5	115	167	175	8,4	50

G1 1/2

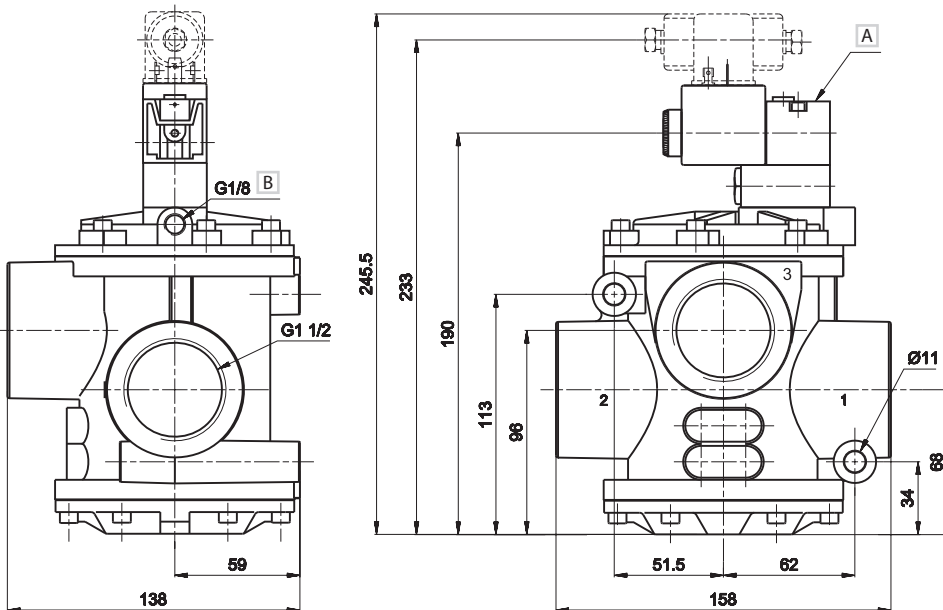

1 = Supply port
 2 = Use
 3 = Exhaust

A Manual override
 B External servoassistance of the pilot

Upon request:
 - external servoassistance of the pilot
 Electrovalves are supplied without coil, connector and locking ring

G1/8 - G1/4 - G3/8 Servo valves

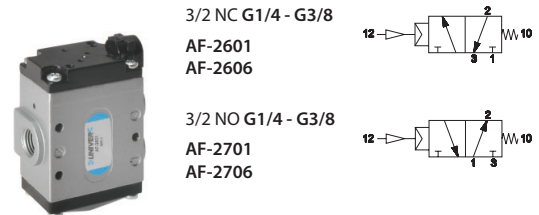
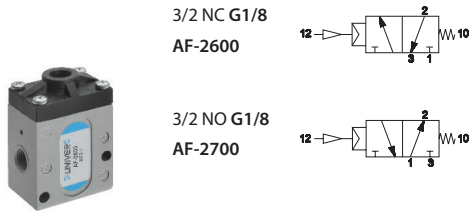

	Connect.	Control	Return	Flow rate (NI/min)	Ø mm	Resp. Time (ms)		Pressure bar		Weight Kg	Part no.
						En.	De-en.	supply	control		
3/2 NC	G1/8	pneumatic amplified	pneumomechanical spring	580	5,5	5	8	6	3,5	0,21	AF-2600
	G1/4	pneumatic amplified	pneumomechanical spring	1100	8	5	7	6	4	0,54	AF-2601
	G3/8	pneumatic amplified	pneumomechanical spring	1500	10	5	7	6	4	0,52	AF-2606
3/2 NO	G1/8	pneumatic amplified	pneumomechanical spring	580	5,5	5	8	6	3,5	0,21	AF-2700
	G1/4	pneumatic amplified	pneumomechanical spring	1100	8	5	7	6	4	0,54	AF-2701
	G3/8	pneumatic amplified	pneumomechanical spring	1500	10	5	7	6	4	0,52	AF-2706

G1/8

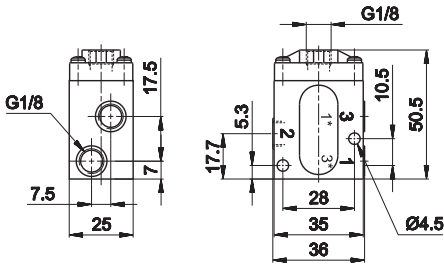

- | | |
|-----------------|------------------|
| NC | NO |
| 1 = Supply port | 1* = Supply port |
| 2 = Use | 2 = Use |
| 3 = Exhaust | 3* = Exhaust |

G1/4 - G3/8

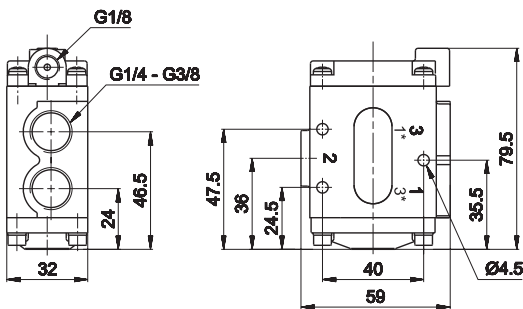

- | | |
|-----------------|------------------|
| NC | NO |
| 1 = Supply port | 1* = Supply port |
| 2 = Use | 2 = Use |
| 3 = Exhaust | 3* = Exhaust |

Upon request:
2/2 version insert plug on the drain

G1/2 - G3/4 - G1 - G1 1/2 Servo valves



3/2 NC-NO G1/2 - G3/4 - G1
 AF-2603
 AF-2610
 AF-2615

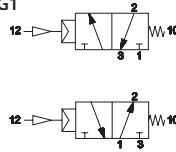

3/2 NC-NO G1 1/2
 AF-2620

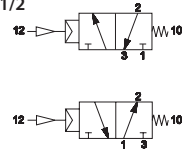

3/2 NC-NO

Connect.	Control	Return	Flow rate	Ø	Resp. Time (ms)		Pressure bar		Weight	Part no.
					En.	De-en.	supply	control		
G1/2	pneumatic amplified	pneumomechanical spring	5400	15	7	10	6	4	1,27	AF-2603
G3/4	pneumatic amplified	pneumomechanical spring	6500	19	7	10	6	4	1,10	AF-2610
G1	pneumatic amplified	pneumomechanical spring	13500	25	10	12	6	4	1,59	AF-2615
G1 1/2	pneumatic amplified	pneumomechanical spring	35000	39	36	15	6	4	2,19	AF-2620

G1/2 - G3/4 - G1

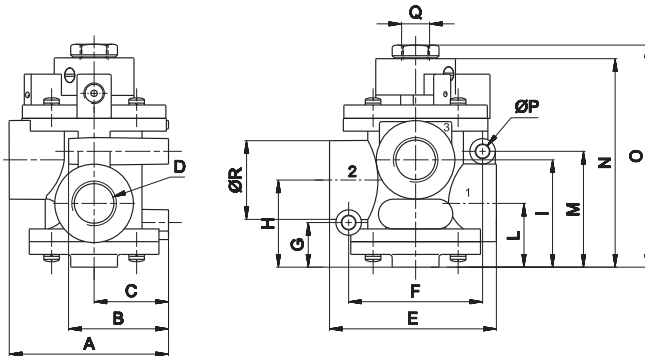

1 = Supply port
 2 = Use
 3 = Exhaust

	A	B	C	D	E	F	G	H	I	L	M	N	O	P	Q	R
G1/2	75	47	35	G1/2	78,5	63	21	41	50,5	30	54,5	100	105	6,4	G1/4	37
G3/4	75	47	35	G3/4	78,5	63	21	41	50,5	30	54,5	100	105	6,4	G1/4	37
G1	88,5	55	40	G1	101	76	25,5	51	64	38	62,5	115	120,5	8,4	G1/4	45

G1 1/2

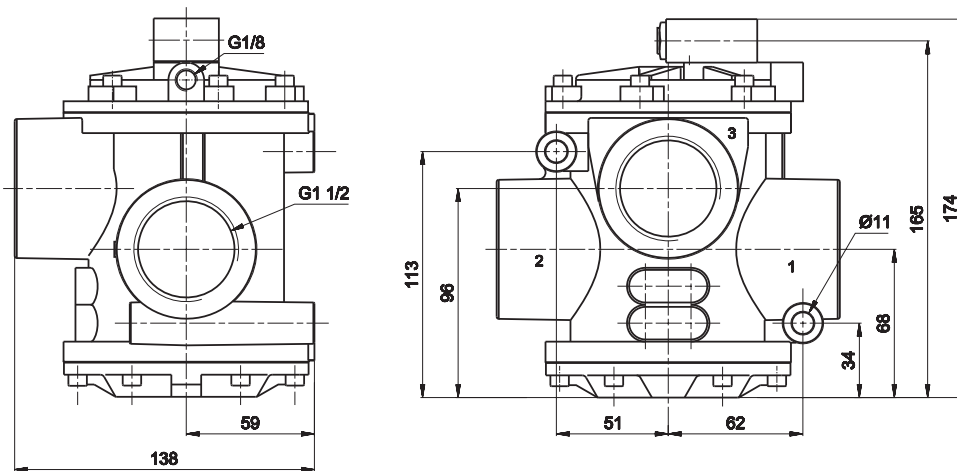

1 = Supply port
 2 = Use
 3 = Exhaust

G1 - 2/2 Electrovalve for blowing

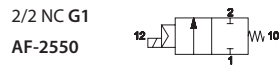

2/2 NC

Connect.	Control	Return	Flow rate	Ø	Resp. Time (ms)			Pressure bar		Weight	Part no.	
					En.	De-en.	min.	max.	supply			control
G1	electric amplified	pneumomechanical spring	16000	25	23	55	2	10	-	-	1,06	AF-2550
G1	electric amplified	pneumomechanical spring	16000	25	23	55	2	10	-	-	1,06	AF-2551
G1	electric amplified	pneumomechanical spring	16000	25	23	35	-	-	6	4	1,06	AF-2552

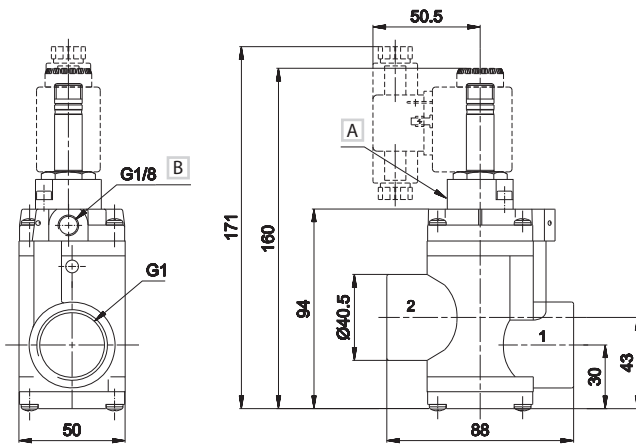

1 = Supply port
2 = Use

- A Manual override AF-2551
- B External servoassistance of the pilot AF-2552

G1 - 2/2 Servovalve for blowing

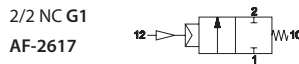

2/2 NC

Connect.	Control	Return	Flow rate	Ø	Resp. Time (ms)			Pressure bar		Weight	Part no.
					En.	De-en.	min.	max.	supply		
G1	pneumatic amplified	pneumomechanical spring	16000	25	12	25	6	4	1	AF-2617	

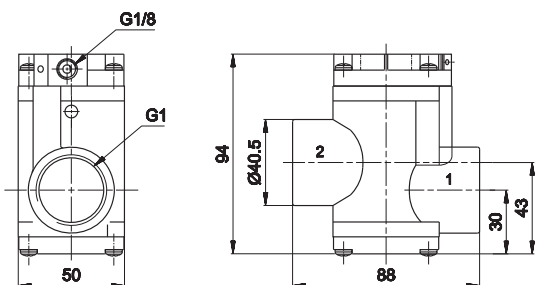

1 = Supply port
2 = Use

Electrovalves are supplied without coil, connector and locking ring

AG

Poppet valves for vacuum G1/8 ÷ G1 1/2

- A complete range: G1/8 - G1/4 - G3/8 - G1/2 - G3/4 - G1 - G1 1/2
- Original Univer poppet system appreciated for decades
- Servoassisted version
- A complete range of solenoid valves and pneumatic valves for vacuum with connection from G1/8 ÷ G1 1/2 to satisfy all requirements
- The internal system ensures high reliability and long life

Available ATEX version upon request

CE Ex II 2Gc IICT5 II 2Dc T100°C

CE Ex II 3 GD c nA II T5-10°C ≤ Ta ≤ 45°C



TECHNICAL CHARACTERISTICS

Ambient temperature								+50 °C
Fluid temperature								-5 ÷ +60 °C
Fluid	50 µm filtered air, with or without lubrication - vacuum							
Commutation system	poppet							
Ways/Positions	2/2 NC (upon request), 3/2 NC, 3/2 NO, 3/2 NC-NO							
Control	indirect vacuum							
Return	automatic by vacuum							
Connections	G 1/8	G 1/4	G 3/8	G 1/2	G 3/4	G 1	G 1 1/2	
Nominal Ø (mm)	5,5	8	10	15	19	25	39	

CONSTRUCTIVE CHARACTERISTICS

Valve body	G1/8 ÷ G1 = zamak G1 1/2 = aluminium
Seals	valve for vacuum with external air operation polyurethane conical poppets and Vulkollan diaphragm valve for direct vacuum with external vacuum operation silicon poppets
Actuators	G1/8 ÷ G1 = zamak G1 1/2 = aluminium
Spool	G1/8 ÷ G3/8 = aluminium G1/2 ÷ G1 1/2 = steel + plastic

ELECTRIC CHARACTERISTICS

	G1/8	G1/4 ÷ G1 1/2
Electropilot	U1	U2
Coil	DA	DB
Power consumption	3,5 W (DC) - 5 VA (AC)	11 W (DC) - 10 VA (AC)
Connector	AM 5110	AM 5111
Voltage	12 V DC - 24 V DC - 24 V AC - 110 V AC - 230 V AC	
Manual override	impulse screw - 2 positions	

3/2 Solenoid valve for vacuum with external pilot air supply



3/2 NC G1/8
AG-3001

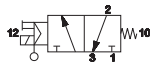

3/2 NO G1/8
AG-3002

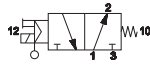

3/2 NC G1/4 - G3/8
AG-3009
AG-3011

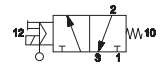

3/2 NO G1/4 - G3/8
AG-3010
AG-3012

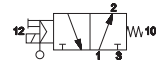

	Connect.	Control	Return	Ø	Resp. Time (ms)		Minimum control pressure bar	Pump max m ³ /h	Max vacuum		Weight Kg	Coil	Part no.
					mm	En.			De-en.	mm Hg			
3/2 NC	G1/8	electric amplified	mechanical spring	5,5	14	25	1,5	1,5	759,5	0,5	0,25	U1	AG-3001
	G1/4			8	16	27	2,5	4	759,5	0,5	0,58	U2	AG-3009
	G3/8			10	16	27	2,5	10	759,5	0,5	0,56	U2	AG-3011
3/2 NO	G1/8	electric amplified	mechanical spring	5,5	14	25	1,5	1,5	759,5	0,5	0,25	U1	AG-3002
	G1/4			8	16	27	2,5	4	759,5	0,5	0,58	U2	AG-3010
	G3/8			10	16	27	2,5	10	759,5	0,5	0,56	U2	AG-3012

G1/8

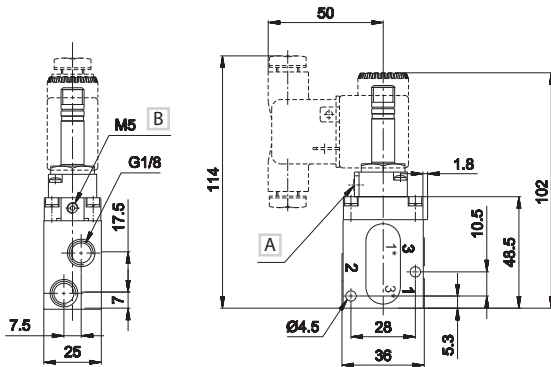

NC

- 1 = Supply port (vacuum)
- 2 = Use
- 3 = Exhaust

NO

- 1* = Supply port (vacuum)
- 2 = Use
- 3* = Exhaust

- A Manual override
- B Supply port for external servoassistance of the pilot

G1/4 - G3/8

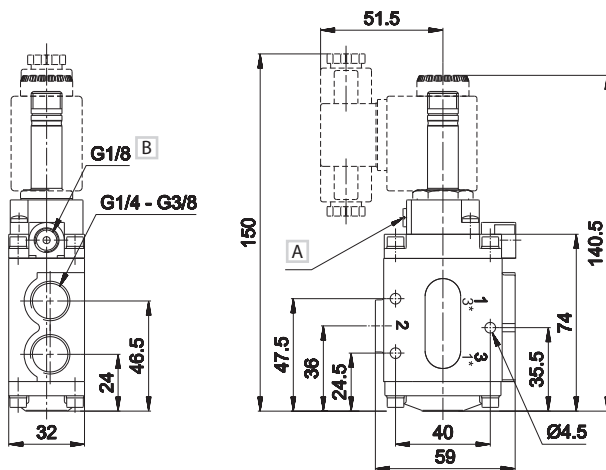

NC

- 1 = Supply port (vacuum)
- 2 = Use
- 3 = Exhaust

NO

- 1* = Supply port (vacuum)
- 2 = Use
- 3* = Exhaust

- A Manual override
- B Supply port for external servoassistance of the pilot

Electrovalves are supplied without coil, connector and locking ring

3/2 Solenoid valve for vacuum with external pilot air supply



3/2 NC G1/2 - G3/4 - G1

AG-3020
AG-3040
AG-3050

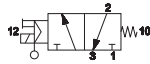

3/2 NO G1/2 - G3/4 - G1

AG-3021
AG-3041
AG-3051



3/2 NC G1 1/2

AG-3062

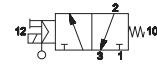

3/2 NO G1 1/2

AG-3063

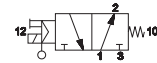

	Connect.	Control	Return	Ø	Resp. Time (ms)		Minimum control		Pump		Max vacuum		Weight	Coil	Part.no
		12	10	mm	En.	De-en.	pressure bar	max m ³ /h	mm Hg	Torr	Kg				
3/2 NC	G1/2	electric amplified	mechanical spring	15	16	40	3	20	759,5	0,5	1,19	U2	AG-3020		
	G3/4			19	16	40	3	35	759,5	0,5	1,13	U2	AG-3040		
	G1			25	18	42	3	90	759,5	0,5	1,62	U2	AG-3050		
	G1 1/2			39	60	38	4	180	759,5	0,5	2,25	U2	AG-3062		
3/2 NO	G1/2	electric amplified	mechanical spring	15	16	40	3	20	759,5	0,5	1,19	U2	AG-3021		
	G3/4			19	16	40	3	35	759,5	0,5	1,13	U2	AG-3041		
	G1			25	18	42	3	90	759,5	0,5	1,62	U2	AG-3051		
	G1 1/2			39	60	38	4	180	759,5	0,5	2,25	U2	AG-3063		

G1/2 - G3/4 - G1

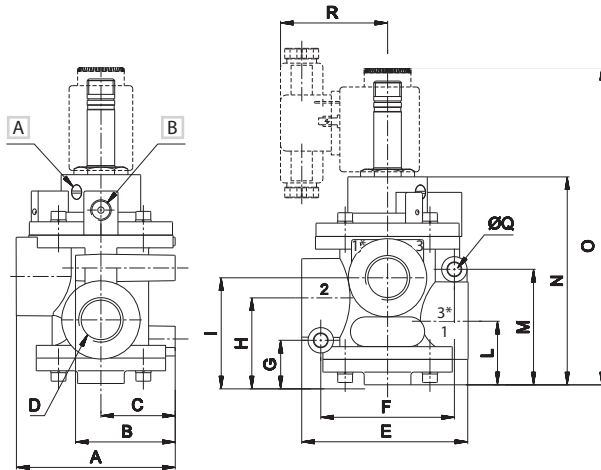

NC
1 = Supply port
2 = Use
3 = Exhaust

NO
1* = Supply port
2 = Use
3* = Exhaust

A Manual override
B Supply port for external servoassistance of the pilot

	A	B	C	D	E	F	G	H	I	L	M	N	O	Q	R
G1/2	75	47	35	G1/2	78,5	63	21	41	50,5	30	54,5	100	150	6,4	50,5
G3/4	75	47	35	G3/4	78,5	63	21	41	50,5	30	54,5	100	150	6,4	50,5
G1	89	55	40	G1	101	76	25,5	51	64	38	62,5	115	167	8,4	50

G1 1/2

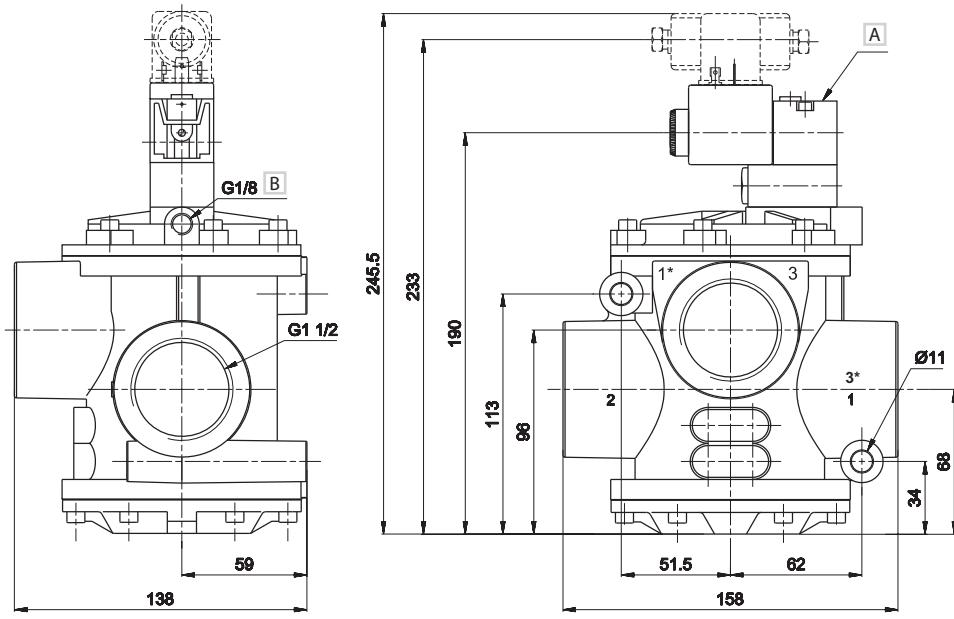

NC
1 = Supply port
2 = Use
3 = Exhaust

NO
1* = Supply port
2 = Use
3* = Exhaust

A Manual override
B Supply port for external servoassistance of the pilot

Electrovalves are supplied without coil, connector and locking ring

3/2 Pneumatic valve for vacuum with external air operation

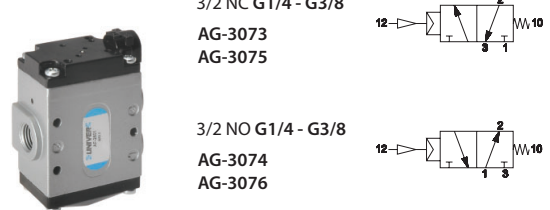
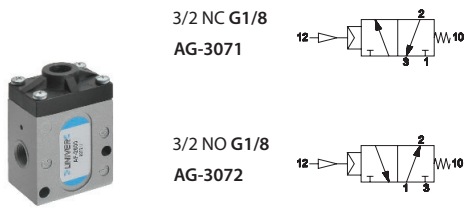

	Connect.	Control	Return	Ø	Resp. Time (ms)		Minimum control pressure bar	Pump max m ³ /h	Max vacuum		Weight Kg	Part no.
					En.	De-en.			mm Hg	Torr		
3/2 NC	G1/8	pneumatic amplified	mechanical spring	5,5	3	6	1,5	1,5	759,5	0,5	0,21	AG-3071
	G1/4			8	4	8	2,5	4	759,5	0,5	0,54	AG-3073
	G3/8			10	4	8	2,5	10	759,5	0,5	0,52	AG-3075
3/2 NO	G1/8	pneumatic amplified	mechanical spring	5,5	3	6	1,5	1,5	759,5	0,5	0,21	AG-3072
	G1/4			8	4	8	2,5	4	759,5	0,5	0,54	AG-3074
	G3/8			10	4	8	2,5	10	759,5	0,5	0,52	AG-3076

G1/8

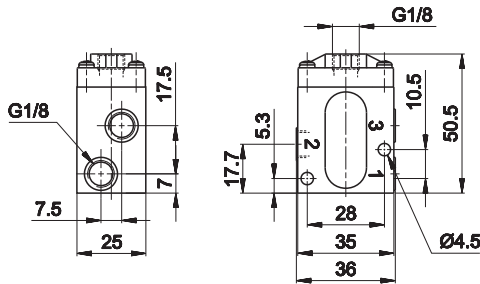

- 1 = Supply port (vacuum)
- 2 = Use
- 3 = Exhaust

G1/4 - G3/8

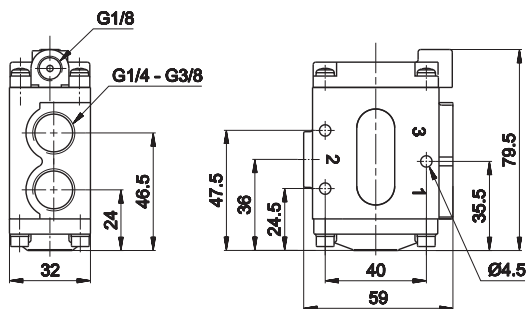

- 1 = Supply port (vacuum)
- 2 = Use
- 3 = Exhaust

3

3/2 Pneumatic valve for vacuum with external air operation



3/2 NC G1/2 - G3/4 - G1

AG-3081
AG-3091
AG-3100

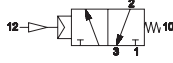

3/2 NO G1/2 - G3/4 - G1

AG-3082
AG-3092
AG-3101

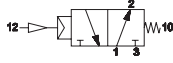

3/2 NC G1 1/2

AG-3110

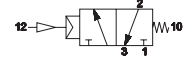

3/2 NO G1 1/2

AG-3111

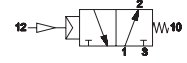

	Connect.	Control	Return	Ø	Times (ms)		Minimum control pressure bar	Pump max m ³ /h	Max vacuum		Weight Kg	Part no.
					En.	De-en.			mm Hg	Torr		
3/2 NC	G1/2	pneumatic amplified	mechanical spring	15	6	15	3	20	759,5	0,5	1,16	AG-3081
	G3/4			19	6	15	3	35	759,5	0,5	1,10	AG-3091
	G1			25	7	16	3	90	759,5	0,5	1,59	AG-3100
	G1 1/2			39	65	25	4	180	759,5	0,5	2,19	AG-3110
3/2 NO	G1/2	pneumatic amplified	mechanical spring	15	6	15	3	20	759,5	0,5	1,16	AG-3082
	G3/4			19	6	15	3	35	759,5	0,5	1,10	AG-3092
	G1			25	7	16	3	90	759,5	0,5	1,59	AG-3101
	G1 1/2			39	65	25	4	180	759,5	0,5	2,19	AG-3111

G1/2 - G3/4 - G1

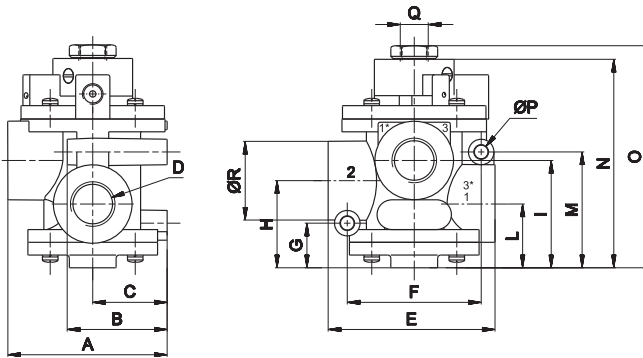

NC

- 1 = Supply port (vacuum)
- 2 = Use
- 3 = Exhaust

NO

- 1* = Supply port (vacuum)
- 2 = Use
- 3* = Exhaust

	A	B	C	D	E	F	G	H	I	L	M	N	O	P	Q	R
G1/2	75	47	35	G1/2	78,5	63	21	41	50,5	30	54,5	100	105	6,4	G1/4	37
G3/4	75	47	35	G3/4	78,5	63	21	41	50,5	30	54,5	100	105	6,4	G1/4	37
G1	88,5	55	40	G1	101	76	25,5	51	64	38	62,5	115	120,5	8,4	G1/4	45

G1 1/2

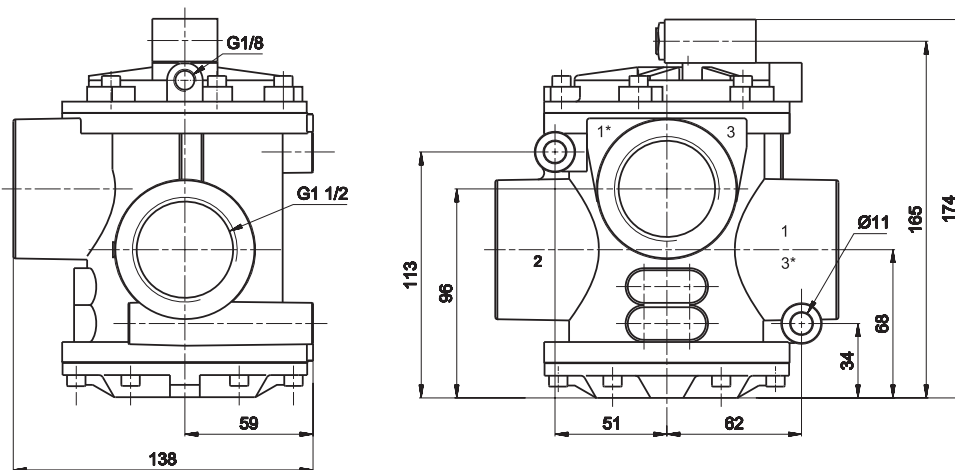

NC

- 1 = Supply port (vacuum)
- 2 = Use
- 3 = Exhaust

NO

- 1* = Supply port (vacuum)
- 2 = Use
- 3* = Exhaust

3/2 Solenoid valve for direct vacuum with pilot vacuum supply

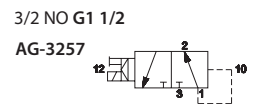
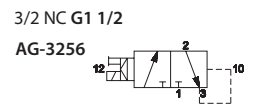
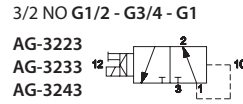
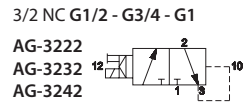
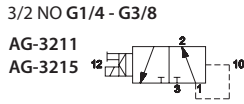
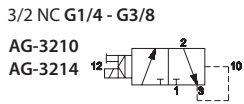

	Connect.	Control	Return	Ø		Resp. Time (ms)		Pump max m ³ /h	Min. vacuum		Max vacuum		Weight Kg	Coil	Part no.
				mm	En.	De-en.	mm Hg		Torr	mm Hg	Torr				
3/2 NC	G1/4	electric amplified	vacuum	8	25	16	4	150	610	759,5	0,5	0,52	U2	AG-3210	
	G3/8			10	25	16	10	150	610	759,5	0,5	0,56	U2	AG-3214	
	G1/2			15	30	15	20	150	610	759,5	0,5	1,19	U2	AG-3222	
	G3/4			19	30	15	35	150	610	759,5	0,5	1,13	U2	AG-3232	
	G1			25	38	18	90	150	610	759,5	0,5	1,62	U2	AG-3242	
	G1 1/2			39	75	50	100	150	610	759,5	0,5	2	U2	AG-3256	
3/2 NO	G1/4	electric amplified	vacuum	8	20	14	4	150	610	759,5	0,5	0,58	U2	AG-3211	
	G3/8			10	20	14	10	150	610	759,5	0,5	0,56	U2	AG-3215	
	G1/2			15	20	18	20	150	610	759,5	0,5	1,19	U2	AG-3223	
	G3/4			19	20	18	35	150	610	759,5	0,5	1,13	U2	AG-3233	
	G1			25	25	20	90	150	610	759,5	0,5	1,62	U2	AG-3243	
	G1 1/2			39	70	60	100	150	610	759,5	0,5	2	U2	AG-3257	

G1/4 - G3/8

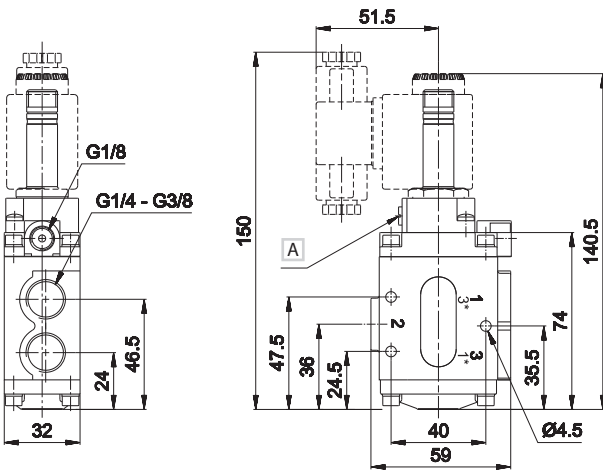

G1/2 - G3/4 - G1

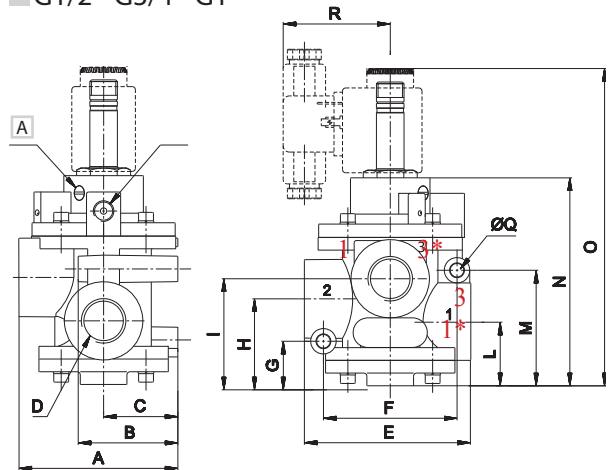

	A	B	C	D	E	F	G	H	I	L	M	N	O	Q	R
G1/2	75	47	35	G1/2	78,5	63	21	41	50,5	30	54,5	100	150	6,4	50,5
G3/4	75	47	35	G3/4	78,5	63	21	41	50,5	30	54,5	100	150	6,4	50,5
G1	89	55	40	G1	101	76	25,5	51	64	38	62,5	115	167	8,4	50

G1 1/2

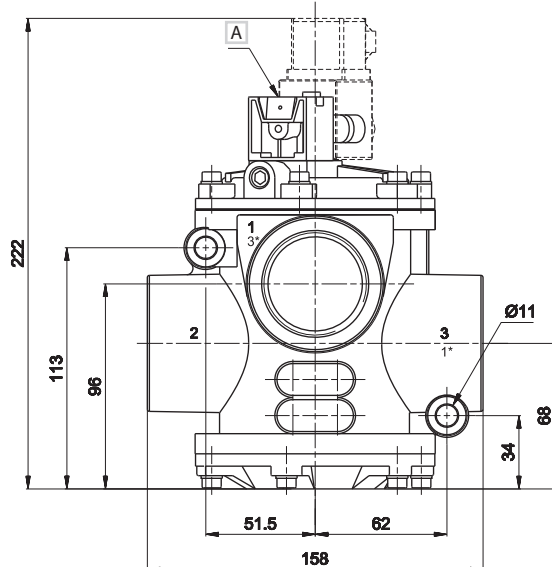
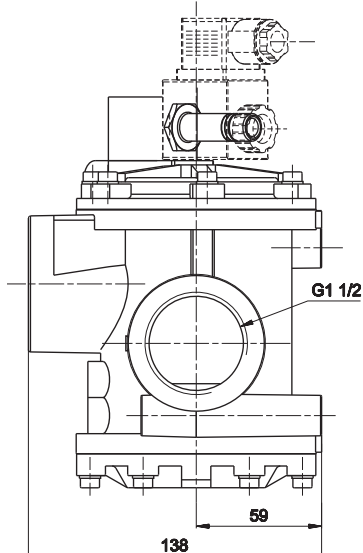

- NC**
1 = Supply port (vacuum)
2 = Use
3 = Exhaust
- NO**
1* = Supply port (vacuum)
2 = Use
3* = Exhaust

A Manual override

For 2/2 version put a cup on the exhaust (3)
Electrovalves are supplied without coil, connector and locking ring

2/2 - 3/2 Solenoid valve for vacuum with direct operation



3/2 NC G1/4
AG-3310
AG-3311
AG-3312
AG-3313

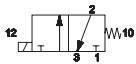

2/2 NC G1/4
AG-3300
AG-3301
AG-3302
AG-3303

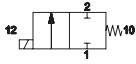

3/2 NC G1/2
AG-3330
AG-3331
AG-3332

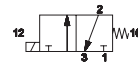

2/2 NC G1/2
AG-3320
AG-3321
AG-3322

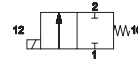

Material:
valve body G1/4 = brass
G1/2 = aluminium
tube/sleeve stainless steel
nucleus and spring stainless steel
seals (a) G1/4 = NBR
G1/2 = vulkollan
(a) = vulkollan + NBR for valves 3/2 version

Connect.	Control	Return	Ø mm	Resp. Time (ms)		Pump max m ³ /h	Max vacuum		Weight Kg	Part no.	
				En.	De-en.		mm Hg	Torr			
3/2 NC	electric	mechanical spring	G1/4	3-3*	10	10	1,8	759,5	0,5	0,22	AG-3310
			G1/4	4-3*	12	8	2,5	759,5	0,5	0,22	AG-3311
			G1/4	5-3*	13	8	4	759,5	0,5	0,22	AG-3312
			G1/4	6-3*	15	8	5	759,5	0,5	0,22	AG-3313
			G1/2	8-3*	17	8	6	759,5	0,5	0,25	AG-3330
			G1/2	10-3*	20	10	7,5	759,5	0,5	0,25	AG-3331
2/2 NC	electric	mechanical spring	G1/4	3	10	-	1,8	759,5	0,5	0,22	AG-3300
			G1/4	4	12	-	2,5	759,5	0,5	0,22	AG-3301
			G1/4	5	13	-	4	759,5	0,5	0,22	AG-3302
			G1/4	6	15	-	5	759,5	0,5	0,22	AG-3303
			G1/2	8	17	-	6	759,5	0,5	0,25	AG-3320
			G1/2	10	20	-	7,5	759,5	0,5	0,25	AG-3321
G1/2	11	28	-	10	759,5	0,5	0,25	AG-3322			

* = solenoid valves with 3 mm fixed exhaust

G1/4

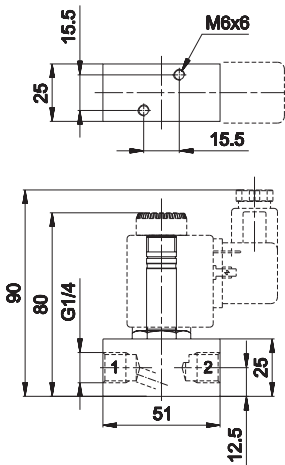

1 = Supply port (vacuum)
2 = Use
3 = Exhaust

G1/2

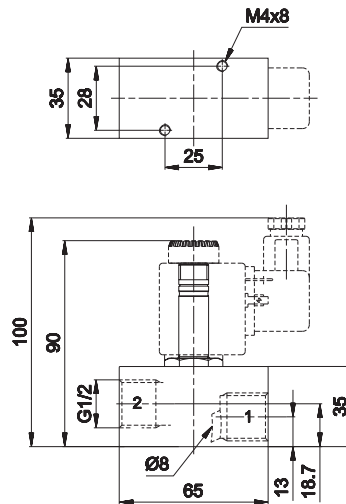

1 = Supply port (vacuum)
2 = Use
3 = Exhaust



Coil U2 - 17 VA

Voltage
24 V CA - 50/60 Hz DB-0607
110 V CA - 50/60 Hz DB-0608
220 V CA - 50/60 Hz DB-0610

Electrovalves are supplied without coil, connector and locking ring

